

## FRIDGE

Owner's Manual



### IMPORTANT

Please read these instructions carefully before assembly, to reduce risk of fire, burn hazard or other injury.

Keep these instructions in a safe place for future use.

# CONTENTS

<b>EXPLODED VIEW</b>	<b>2</b>
<b>PRODUCT INTRODUCTION</b>	<b>3</b>
<b>INSTALLATION</b>	<b>3</b>
<b>DIRECTIONS FOR USE</b>	<b>4</b>
<b>APPLICATION NOTICE</b>	<b>4</b>
<b>MAINTENANCE</b>	<b>4</b>
<b>STRUCTURE</b>	<b>4</b>
<b>TROUBLE SHOOTING</b>	<b>5</b>

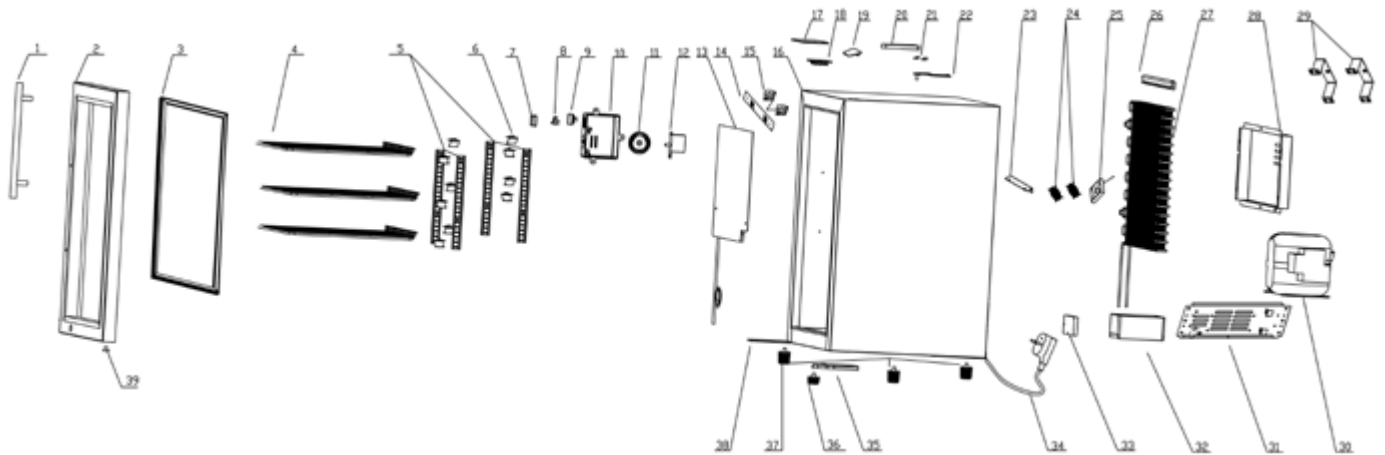

## EXPLODED VIEW

1. Handle
2. Door Assembly
3. Door gasket
4. Layer of steel wire rack
5. Carriage
6. Upright post
7. Waterproof jacket
8. Ship type switch
9. Knob
10. Electrical box
11. Sensor cap
12. Mechanical thermostat
13. Evaporator
14. Fan shield
15. Blower fan
16. Casing
17. Light cover
18. LED light
19. Top cover

20. Hinge Cover
21. Recalls stop
22. Upper Hinger
23. Fan bracket
24. Fan cover
25. 8025-FAN
26. The condenser back card
27. Condenser
28. Compressor cover
29. Rear bracket of outer case
30. Compressor
31. Compressor Support plate
32. Water tray
33. Electric board
34. Power supply cord
35. Down Hinger
36. Front Foot
37. High foot
38. The lock bracket
39. Shaft sleeve

## PRODUCT INTRODUCTION

- This product has been manufactured with advanced refrigeration technology, this allows for a wide temperature range with low power consumption.
- The outer casings are made from durable stainless steel giving good anti corrosion properties.
- The blue coloured LED lighting allows good visibility inside the fridge. This cooler uses the roll-bond evaporator which is efficient and fast refrigerating.
- The doors glass to avoid any condensation and make the goods in coolers more visible.

### IMPORTANT SAFETY PRECAUTION WARNINGS

WHEN USING THIS APPLIANCE ALWAYS EXERCISE BASIC SAFETY PRECAUTIONS INCLUDING THE FOLLOWING:

- DANGER THIS APPLIANCE IS NOT INTENDED FOR USE BY PERSONS (INCLUDING CHILDREN) WITH REDUCED PHYSICAL, SENSORY OR MENTAL CAPABILITIES, OR LACK OF EXPERIENCE AND KNOWLEDGE, UNLESS THEY HAVE BEEN GIVEN SUPERVISION OR INSTRUCTION CONCERNING USE OF THE APPLIANCE BY A PERSON RESPONSIBLE FOR THEIR SAFETY.
- YOUNG CHILDREN SHOULD BE SUPERVISED TO ENSURE THEY DO NOT PLAY WITH THE APPLIANCE.
- THE MANUFACTURER'S INSTALLATION INSTRUCTIONS FOR PRODUCT AND CABINERY VENTILATION MUST BE FOLLOWED WHEN INSTALLING THE APPLIANCE.
- KEEP VENTILATION OPENINGS, IN THE APPLIANCE ENCLOSURE OR IN THE BUILT-IN STRUCTURE, CLEAR OF OBSTRUCTION.
- DO NOT USE MECHANICAL DEVICES OR OTHER MEANS TO ACCELERATE THE DEFROSTING PROCESS.
- DO NOT DAMAGE THE REFRIGERANT CIRCUIT. IN CASE OF DAMAGE TO THE REFRIGERANT CIRCUIT, VENTILATE THE AREA BY OPENING ALL WINDOWS. DO NOT OPERATE ELECTRICAL EQUIPMENT OR ANY OTHER EQUIPMENT THAT MAY PRODUCE ARCS, SPARKS OR FLAMES IN THE AREA.

### DISPOSAL

EXTREME CARE MUST BE TAKEN WHEN DISPOSING YOUR OLD APPLIANCE TO AVOID HAZARDS:

- THE REFRIGERANT GAS MUST BE SAFELY REMOVED
- THE DOORS SHOULD BE REMOVED AND THE SHELVES LEFT IN PLACE SO THAT CHILDREN MAY NOT EASILY CLIMB INSIDE.

### CLEANING

MANY COMMERCIALY AVAILABLE CLEANING PRODUCTS CONTAIN SOLVENTS WHICH MAY ATTACK COMPONENTS.

### ELECTRICAL

- THIS APPLIANCE MUST BE INSTALLED IN ACCORDANCE WITH THE INSTALLATION INSTRUCTIONS BEFORE USE. NEVER UNPLUG YOUR REFRIGERATOR BY PULLING ON THE POWER CORD. ALWAYS GRIP THE PLUG FIRMLY AND PULL STRAIGHT OUT FROM THE OUTLET.
- DO NOT PLUG IN ANY OTHER APPLIANCE AT THE SAME POWER POINT AS YOUR REFRIGERATOR OR USE EXTENSION CORDS OR DOUBLE ADAPTERS.
- REPAIR OR REPLACE IMMEDIATELY ALL ELECTRIC SERVICE CORDS THAT HAVE BECOME FRAYED OR OTHERWISE DAMAGED.
- DO NOT USE A CORD THAT SHOWS CRACKS OR ABRASION ALONG ITS LENGTH OR AT EITHER THE PLUG OR APPLIANCE END.
- WHEN MOVING YOUR APPLIANCE AWAY FROM THE WALL, BE CAREFUL NOT TO ROLL OVER OR DAMAGE THE POWER CORD.
- DO NOT USE ELECTRICAL APPLIANCES INSIDE THE FOOD STORAGE COMPARTMENTS OF THE APPLIANCE.

## INSTALLATION

### Transport

- Turn off the appliance and unplug before moving
- The inclination shall not exceed 45°
- Please handle with care. Protect the glass door.



### Moving

Avoid putting pressure on the glass



Remove everything from inside the cooler before moving.



### Levelled

The cooler shall be put in a levelled place with good ventilation.



### Installation



Remove the packing material, place the cooler on a solid and levelled surface.



Install in a dry, well ventilated area

### Power Requirements



For normal use, the power should be 230V - 240V, 50Hz and equipped with the triplex receptacle (250V, 10A) and fuse (6A), power socket should have a reliable grounding line.

### Warning



Do not place heavy objects on the electrical cord, Avoid moving the appliance wheels over the cord. On case of damage to the cord, replace immediately.



Do not store flammable or explosive materials near the appliance.

### Sockets

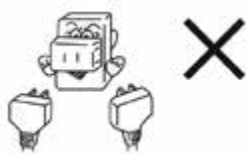

Do not plug in any other appliance at the same power point as your refrigerator or use extension cords or double adapters.

### Keep Dry



Avoid pouring water on the appliance - danger of electrical shocks.

### Flammables



Don not spray combustible and explosive goods, such as paint or oil near the cooler.

### Outages



In case of a power outage, allow a minimum of 5 minutes before reconnecting the appliance.

## DIRECTIONS FOR USE

#### Application method:

Before connecting the power, please check the power line, the light switch and the thermostat switch knob show no damage.

#### Temperature setting:

The temperature setting has 1~6 positions, the first is the maximum temperature and the sixth is the minimum temp. You can adjust according to your needs

#### Setting of power and light:

Slide the switch control ON or OFF.

Turn the fridge off when not being used.

The fridge has an operating range of approximately 1-9°C

Switch of LED light

Thermostat switch knob

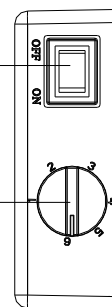

## APPLICATION NOTICE

1. A damaged power cord must be replaced by an authorised electrician.
2. Don't touch the compressor - danger of burns or injury.
3. Please keep the heating panel (the left and right sides of the plate in the cooler) clean, otherwise it will affect the refrigerating temperature.
4. When not in use for a long time:
  - Remove all items from the cooler and unplug the power plug.
  - Please clean the inside and outside of the cooler and make it fully dry
  - Store away from the children's play area.
5. Don't damage the refrigeration cycle pipe. If this part is broken, it will lead to the leakage of the refrigerant agent.

## MAINTENANCE

For safety, please unplug it before cleaning

- Clean the cooler internal and external surfaces and the inner casing.
- Use a damp soft cotton fabric to wipe. Dry thoroughly with a dry cloth.
- Please clean and maintain the cooler regularly.
- Please use a neutral detergent to clean it.
- Clean plastic parts of any residues regularly to avoid aging and cracking.
- The following items will damage the cooler's surface: Alkaline detergent, toilet soap, milled powder, boiling water, sweeper, lacquer thinner, acetone, methyl benzene and so on.



## STRUCTURE

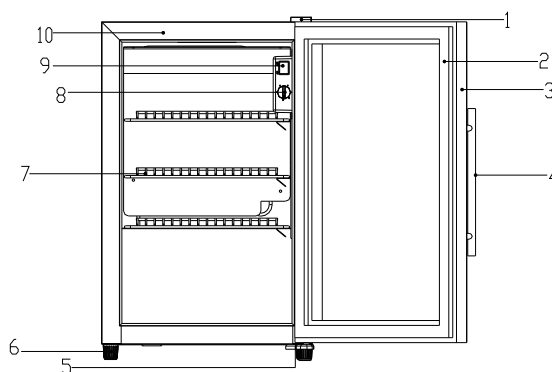

1. Up Hinge; 2 Door Sealing; 3 Door Frame; 5 Down Hinge; 6 Foot; 7 Rack; 8 Thermostat switch knob; 9 Switch of LED light; 10 Casing

The appearance of the units that you purchase might be slightly different from the Manual, but it does not affect your proper operations and usage.

# TROUBLE SHOOTING

Problem	Solution
Not Working	Ensure plugged in
	Fuse break
	No Power
Cooling Problem	Heat source near the item
	Restricted ventilation
	Door open for too long or not closed properly
	Door sealing problem or deformation
	Too many bottles loaded onto one shelf
	Air inlet or outlet blocked
	Control setting problem
	Ventilation space in the right & left casing not enough
Noisy	Wine cabinet not placed flat
	Item touching the wall
	Some parts may be loose or have been taken off

Note: The following situations indicate normal operation:

#### Liquid sound

- 1 The sound of compressor when starts or stops working
- 2 The flowing sound of refrigerant in the refrigeration system
- 3 The evaporating sound of refrigerant in the evaporator

#### Dew on the surface of cabinet

Frost may appear on the cabinet or on the glass door if the cooler is operated in a damp room. This is due to the moisture in the air coming into contact with the cabinet. Please wipe it away with dry cloth.

#### Condensation formed inside the cabinet

Condensation can form inside the cabinet if:

- Door has been left open for a long time
- Door is opened frequently
- Appliance is operated in a high humidity environment.

Wipe dry the condensation with a soft cloth.

#### Adjustment of door(if needed)

Tools required: Pliers and a phillips screwdriver

Step1: Open the upper cover, then use the pliers firmly to hold the spring. Once the spring is held, loosen the screw on the outside edge.

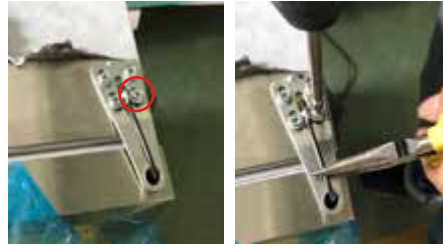

Step2: Once the screw has been loosened, use the pliers to bend the spring a little more which will give it extra tension.



Step3: Use the pliers to firmly hold the spring whilst securing the screw.





# OWNER'S WARRANTY

## For Barbecue Products

### THE MASPORT EXPRESS WARRANTY BARBECUE PRODUCTS

#### 1. Warranty provider

- 1.1 The Express Warranty set out below is provided by Masport Limited, a New Zealand company located at 1-37 Mt Wellington Highway, Panmure 1060, Auckland, New Zealand. For any questions regarding this Express Warranty or to make a warranty claim call 0800 627 767 (New Zealand) or 1300 366 225 (Australia), or contact your local Masport Specialist Retailer.

#### 2. General warranty coverage

- 2.1 The New Zealand Consumer Guarantees Act 1993 ("New Zealand Consumer Act") and the Australian Competition and Consumer Act 2010 (including the Australian Consumer Law 2011) ("Australian Consumer Law"), as well as other laws in each of those jurisdictions, guarantee or imply certain conditions, warranties and undertakings, and give you other legal rights, in relation to the quality and fitness for purpose of our products sold in New Zealand and Australia respectively.
- 2.2 For products sold in New Zealand, these conditions, warranties and undertakings cannot be modified or excluded by any contract, except in those circumstances contemplated by section 43(2) of the New Zealand Consumer Act.
- 2.3 For products sold in Australia, our goods come with guarantees that cannot be excluded under the Australian Consumer Law. You are entitled to a replacement or a refund for a major failure and for compensation for any other reasonably foreseeable loss or damage. You are also entitled to have the goods repaired or replaced if the goods fail to be of acceptable quality and the failure does not amount to a major failure. What constitutes a major failure is set out in the Australian Consumer Law.

#### 3. Express Warranty

- 3.1 Masport warrants to you that each Product will be free from material defects in workmanship or materials from the date the Product is originally purchased for a period of 12 months ("Express Warranty")
- 3.2 Despite the warranty period listed above, where the Product is used for business, commercial, industrial, institutional, rental or other income-producing purposes, the warranty period for each Product is 3 months from the date the Product is originally purchased.
- 3.3 Masport will repair or replace (at Masport's sole option) any Product that does not comply with the Express Warranty. The repair or replacement by Masport may be performed by a Masport agent or Specialist Retailer. You will not be charged for any labour costs involved in the repair or replacement but must bear the cost of transporting or delivering the Product to and from the location of the Masport agent or Specialist Retailer where the warranty claim is made.
- 3.4 Masport warrants that repair facilities and spare parts will be made available for each Product only from the date the Product is originally purchased until the end of the applicable warranty period as set out in the table above or in clause 3.2, but for no longer period.

#### 4. Exclusions from Express Warranty

- 4.1 No warranty is given under clause 3 where any defect, malfunction or failure is caused or contributed to by any of the following:
- (a) warranty excludes batteries;
  - (b) modification, repairs or alteration of the Product carried out by persons other than authorised Masport service agents;
  - (c) acts or omissions by anyone other than Masport after the Product has left Masport's control;
  - (d) normal wear and tear;
  - (e) accidental damage, neglect, misuse;
  - (f) any event outside of Masport's reasonable control, including without limitation, adverse weather conditions;
  - (g) pre-delivery assembly of the Product by anyone except for Masport, Masport authorised service agents or any other person authorised by Masport.

#### 5. Express Warranty in addition to consumer protection laws

- 5.1 Despite anything else in this warranty card, nothing in this warranty card will exclude, limit or modify any Consumer Protection Warranty or any liability of Masport imposed by applicable law if to do so would be unlawful or make any part of this warranty card void or voidable.

**IMPORTANT. Please read the Owner's Manual and Warranty before using this product. The Warranty does not cover damage due to misuse or failure to follow the instructions.**

5.2 The Express Warranty is in addition to any Consumer Protection Warranty that may apply, for example, under the New Zealand Consumer Act or the Australian Consumer Law, or under the laws of the place where the Product was purchased. To the extent permitted by applicable law, Masport's liability under any Consumer Protection Warranty will be limited (at Masport's sole option) to Masport repairing or replacing the relevant Product or paying for such repair or replacement.

#### **6. No other warranties or liability**

6.1 Subject to Clause 5, Masport excludes all express or implied warranties, guarantees, conditions or terms in relation to the Product. All statements, technical information and recommendations about the Product are believed to be reliable, but do not constitute a guarantee or warranty. No statements, representations or recommendations other than those contained in the official technical information published by Masport, will bind Masport, unless made in writing signed by an authorised representative of Masport.

6.2 Subject to Clause 5, in no event will Masport be liable (whether in contract, tort, negligence or in any other way) for:

- (a) loss of profits or savings, loss of goodwill or opportunity, loss of production or wasted time; or
- (b) loss, damage, cost or expense of any kind whatsoever which is indirect, consequential, or of a special nature, arising directly or indirectly from the Product, even if Masport had been advised of the possibility of such damages.

6.3 Subject to Clause 5, in no event will Masport's total liability under any claim of whatever nature arising directly or indirectly from the Product exceed the price you paid for the Product.

6.4 This warranty card embodies the entire agreement between you and Masport in relation to the subject matter of this warranty card and supersedes all prior understandings, communications and representations between you and Masport, whether oral or written. No amendment to this warranty card will be effective unless in writing and signed by an authorised representative of Masport. You may not assign or transfer the Express Warranty without the prior written consent of Masport. This warranty card will be governed by the law of New Zealand and Australia, and will be subject to the non-exclusive jurisdiction of the New Zealand and Australian courts.

#### **7. How to obtain service for a faulty Product**

7.1 You must return the Product to the place of purchase or any Masport Specialist Retailer, along with reasonable evidence of the date the Product was purchased, for example, an original receipt.

7.2 Masport or its agent will assess the claim and if accepted, will repair or replace the Product in accordance with the normal practices of the relevant Masport service agent.

7.3 All claims under the Express Warranty must be made within the relevant warranty period.

#### **8. Definitions**

In this warranty card:

8.1 "**Consumer Protection Warranty**" means any warranty, guarantee, term, condition, right or remedy implied or imposed by applicable law;

8.2 "**Express Warranty**" means the warranty in Clause 3.1;

8.3 "**Masport**" means Masport Limited, a New Zealand company located at 1-37 Mt Wellington Highway, Panmure 1060, Auckland, New Zealand with an Australian office located at 1/40 Abbots Road, Dandenong South, Victoria 3175, Australia;

8.4 "**Product**" means the Masport product accompanying this warranty card;

8.5 "**You**" means the original purchaser of the Product.

**Thank you for purchasing your Masport product. We know that you'll enjoy it!  
To register your product warranty, simply visit our website: [www.masport.com](http://www.masport.com).**

Failure to register your product warranty will not affect your rights under any Consumer Protection Warranty, however registration may help Masport deal with any warranty claim more efficiently.

The logo for Masport, featuring the word "Masport" in a bold, italicized, white font with a thick black outline. A registered trademark symbol (®) is located at the top right of the letter 't'.

**Masport<sup>®</sup>**

Masport Limited  
1-37 Mt Wellington Highway  
Panmure  
Auckland 1060  
New Zealand  
P: 0800 627 767 (New Zealand)  
P: 1300 366 225 (Australia)